

MPL-F-355/0.1~15uJ/1~150mW

LD PUMPED ALL-SOLID-STATE UV LASER



All solid state 355 nm UV laser is made features of ultra compact, long lifetime, low cost and easy operating, which is widely used in UV curing, micro-electronics, CD carving, laser medical treatment, scientific experiment, etc.



SPECIFICATIONS

Wavelength (nm)		355±1
Output average power (mW)		1~150
Transverse mode		Near TEM ₀₀
Operating mode		Frequency conversion of Q-switched pulsed laser
Single pulse energy (μJ)		0.1~15
Pulse duration (ns)		~7
Peak power(kW)		~2
Rep. rate (kHz)	Controllable	Fixed rep. rate, such as 1k, 2k, 3k, 4kHz, with stable laser pulses emitting (stable pulse energy, peak, duration and period). Different rep. rate in the range of 1kHz-4kHz can be obtained by input an external TTL signal.
	Uncontrollable	Undefined rep. rate among 4k-10kHz and unstable laser pulse emitting. Suitable for the applications only needing high peak power pulses.
Average power (mW)		Average power (mW) = Single pulse energy (μJ) * Rep. rate (kHz)
Ave power stability (over 4 hours)		<5%, <10%
Beam divergence, full angle (mrad)		<1.5
Beam diameter at the aperture (mm)		~2.0
Polarization ratio		>100:1
Pointing stability after warm-up (mrad)		<0.05
Warm-up time(minutes)		<10
Beam height from base plate (mm)		45
Operating temperature (°C)		10~35
Spectral purity		>99%
Power supply (90-264VAC)		PSU-H-FDA
Expected lifetime (hours)		10000
Warranty period		1 year
Remarks		Please Note: because of the Walk-off effect of Nonlinear crystals, the beam quality of UV laser is not so good as that of 1064/532nm laser.

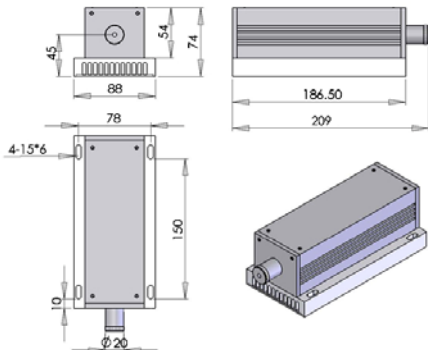

MxL-F-355		PSU-H-FDA	
 <p>209(L)×88(W)×74(H) mm³, 1.6 kg</p>		 <p>238 (L) ×146(W) ×102 (H) mm³, 2.3 kg</p>	