

LPS-A-532/10-80mJ

## HIGH ENERGY LAMP PUMPED SOLID STATE Q-SWITCHED LASER

High energy lamp pumped solid state Q-switched laser at 532nm has the features of high single pulse energy, short pulse duration, high peak power, and air cooling, which is widely used in scientific research and so on.





### SPECIFICATIONS

|                                    |  |      |      |      |
|------------------------------------|--|------|------|------|
| Wavelength (nm)                    | 532±1                                      |      |      |      |
| Operating mode                     | Q-switched: EOM (Electro-optic modulation) |      |      |      |
| Single pulse energy (mJ)           | 10   | 30   | 50   | 80   |
| Pulse duration (ns)                | <10  | <10  | <10  | <10  |
| Rep. rate (Hz)                     | 1~10 (adjustable)                          |      |      |      |
| Energy stability                   | ≤5%  |      |      |      |
| Warm-up time (minutes)             | <15  |      |      |      |
| Beam divergence, full angle (mrad) | ~1.5                                       | ~1.0 | ~1.0 | ~1.0 |
| Beam diameter (mm)                 | <6   | <6   | 7    | 7    |
| Beam height from base plate (mm)   | 118  |      |      |      |
| Cooled method                      | Air Cooling                                |      |      |      |
| Operating temperature (°C)         | 20~30                                      |      |      |      |
| Power supply (220/110VAC)          | PSU-LPS-A(3U)                              |      |      |      |
| Expected lifetime (hours)          | 10000                                      |      |      |      |
| Warranty period                    | 1 year                                     |      |      |      |
| Available options                  | Jitter-1ns, Sdev                           |      |      |      |

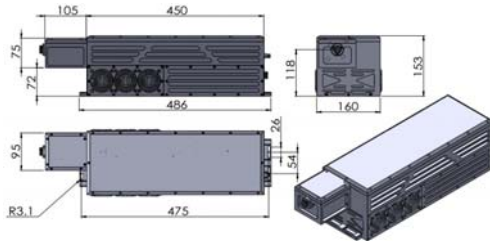

If you have any further requirement about the specification, please contact CNI sales.

| LPS-A-532  |  | PSU-LPS-A (3U)   |
|--|--|--|
|  <p style="text-align: center;">590 (L) ×160(W) ×153(H) mm<sup>3</sup>, 15 kg</p> |  |  <p style="text-align: center;">480 (L) ×450(W) ×150(H) mm<sup>3</sup>, 15kg</p> <p style="text-align: center;">Rep. rate and Voltage can be adjusted by touch screen</p> |