



# OZ Optics

www.ozoptics.com

219 Westbrook Rd, Ottawa, ON, Canada, K0A 1L0 Toll Free: 1-800-361-5415 Tel:(613) 831-0981 Fax:(613) 836-5089 E-mail: sales@ozoptics.com

## HERMETICALLY SEALABLE PATCHCORDS WITH METAL SOLDER

### Features:

- Singlemode, multimode, or polarization maintaining fibers
- Single or multiple fiber designs
- Can be installed into packages with standard solders
- Gold plated seal tube for easy sealability and corrosion resistance
- Designed to meet Telcordia requirements
- Available terminated with round or rectangular ferrules
- Custom configurations can be designed
- Large volume manufacturing capacity
- Low cost

### Applications:

- Laser diode packaging
- Waveguide packaging
- Integrated optics packaging
- Vacuum feedthrough assemblies

### Customer Support:

OZ Optics offers consulting services for custom designed soldering systems, including a wide range of materials and supplies.

### Product Description:

OZ Optics' hermetically sealable patchcords are designed for today's stringent requirements for component packaging. Utilizing metalized fiber and a proprietary sealing process, these patchcords feature a rugged hermetic feedthrough that can be soldered into an opto-electronic package using standard tin/lead solders. The hermetic seal tube is gold plated to promote good on-site sealing and corrosion resistance. These assemblies are capable of easily creating a seal that meets industry hermeticity requirements.

OZ Optics' hermetically sealable patchcords are available with singlemode, multimode or polarization maintaining (PM) fibers. PM fibers offer a means to control polarization of optical signals throughout the system, thus controlling Polarization Dependent Losses (PDL) and Polarization Mode Dispersion (PMD). This control is crucial in developing high speed, 10 Gbs, 40 Gbs, and faster systems.

In general, OZ Optics uses polarization maintaining fibers based on the PANDA fiber structure when building polarization maintaining components and patchcords. However OZ Optics can construct devices using other PM fiber structures. We do carry some alternative fiber types in stock, so please contact our sales department for availability. If necessary, we are willing to use customer supplied fibers to build devices.

As a new, unique service, OZ Optics now offers hermetic sealable patchcords with built-in optical taps for power monitoring. This allows one to tap a small percentage of light from the fiber inside the assembled component (See page 6). This is ideal for applications such as power monitoring the output power from a packaged laser diode assembly. It provides a more precise means of monitoring the signal intensity, as signals seen by the directional tap are not influenced by return losses from the fiber output, which

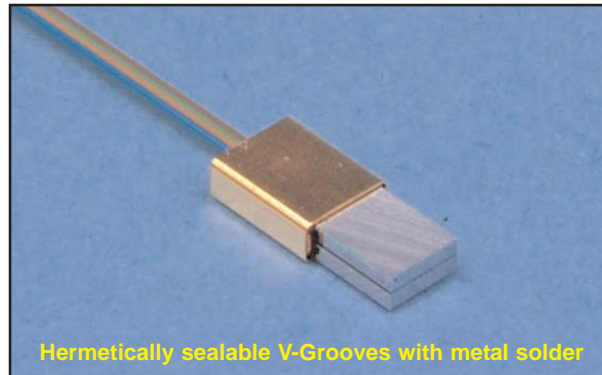

Hermetically sealable V-Grooves with metal solder



Hermetically sealable patchcords with metal solder, 0.9mm jacketed with 1.4mm OD circular Zirconia ferrule



Hermetic Patchcord With Built-in Optical Tap

otherwise would be seen in conventional laser diode modules. The main device and the monitor photodiode are packaged into a single housing, reducing both size and costs.

To the best of our knowledge, this is the only technology available to make this possible. A novel patent pending manufacturing process allows full automation, sharply reducing costs. For additional information, please refer to our data sheet titled *Inline Optical Taps and Monitors*.



Rectangular glass ferrule



1.4mm OD circular zirconia ferrule



Gold plated Kovar feedthroughs

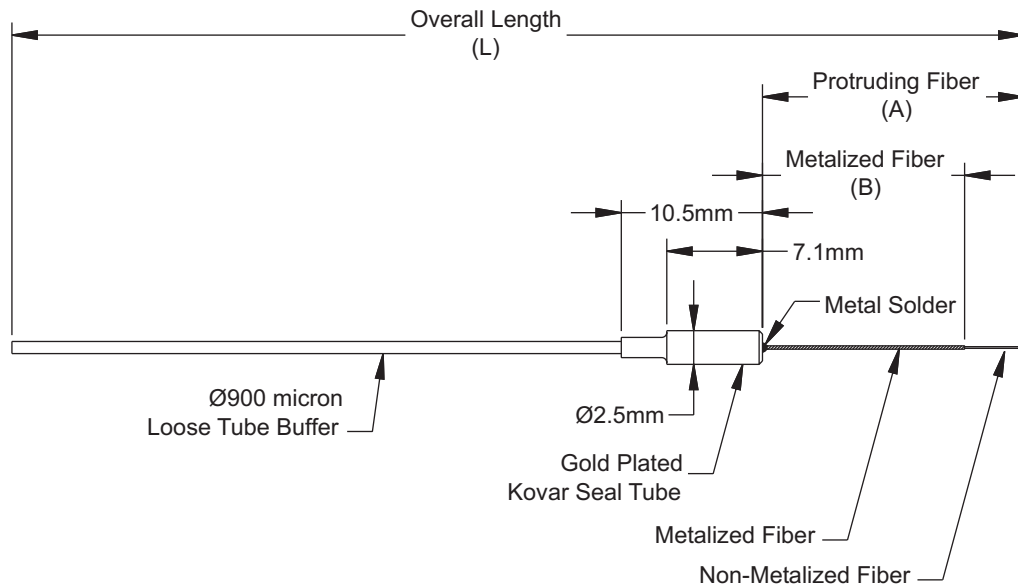

**Figure 1: 900 Micron Jacketed Hermetic Patchcord With Metal Solder, Standard 2.5mm Kovar Ferrule**

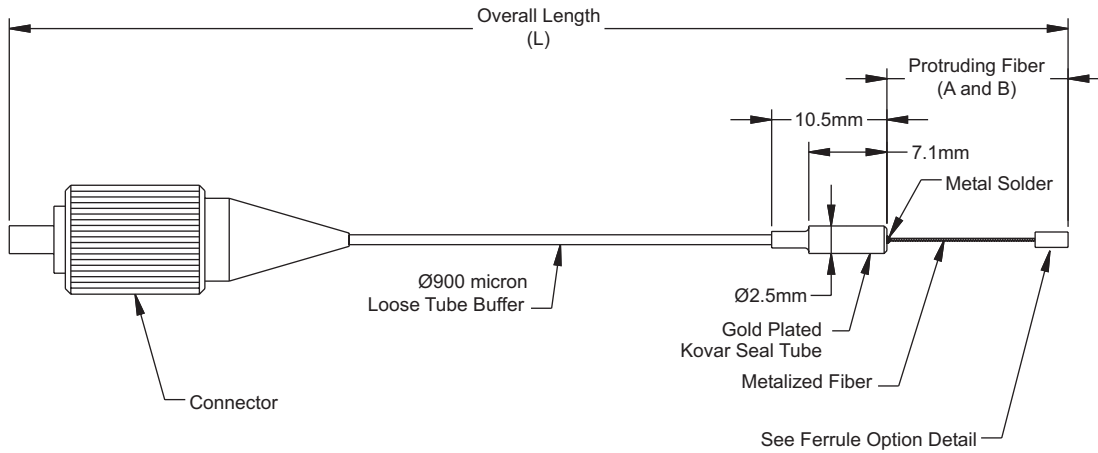

**Figure 2: 900 Micron Jacketed Hermetic Patchcord With Metal Solder Including Connector And Ferrule (Puck)**

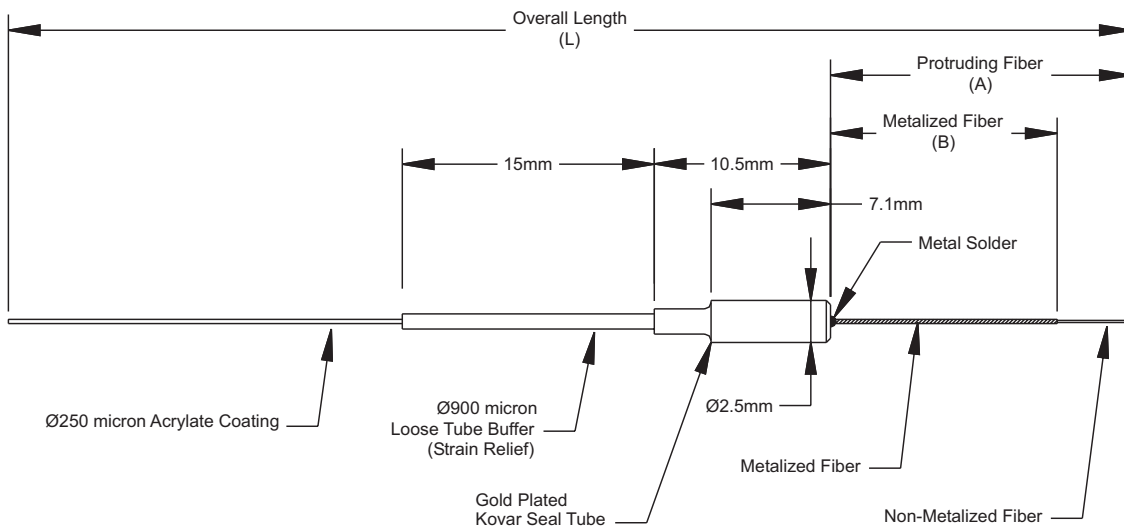

**Figure 3: 250 Micron Bare Fiber Hermetic Patchcord with Metal Solder, Standard 2.5mm Kovar Ferrule**

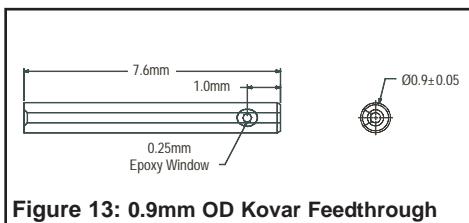
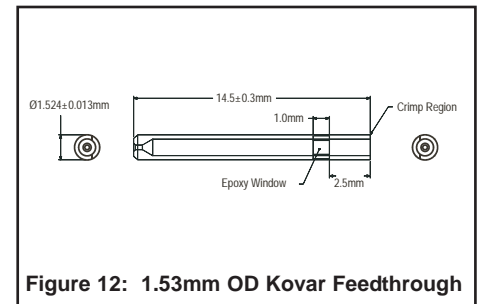
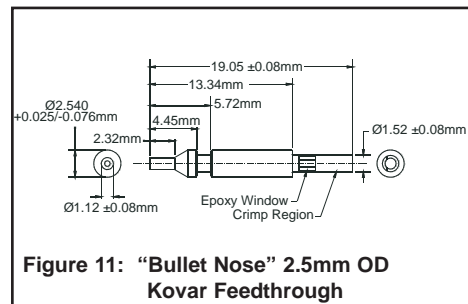
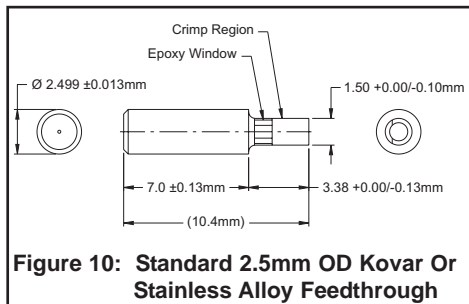
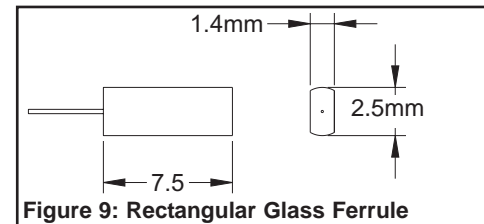
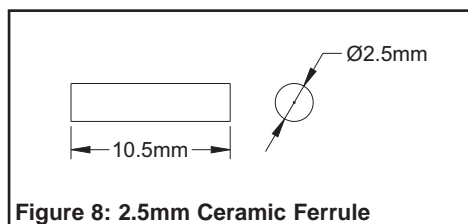
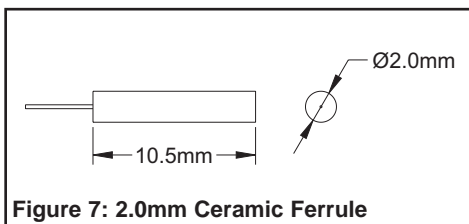
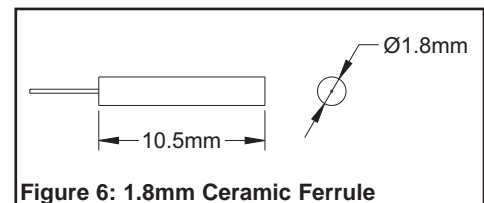
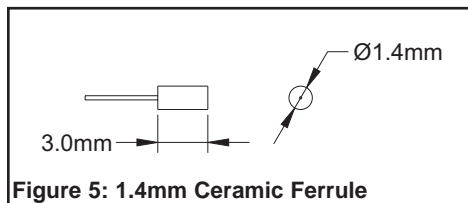
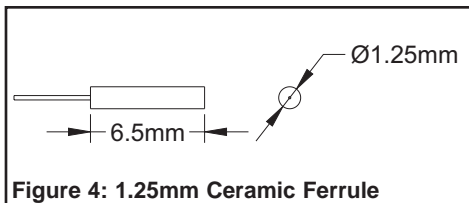

### Ordering Information For Standard Parts:

Bar Code	Part Number	Description
12595	HSMJ-3A-1300/1550-9/125-1-C1.4-14-11-1-2.5KO	1 meter long, 1mm OD jacketed 1300/1550nm 9/125um Corning SMF-28 fiber patchcord with an Angle FC/PC connector on one end, metal soldered tip on the other end. Protruding fiber length is 14mm, metalized fiber length is 11mm, gold plated kovar OD is 2.5mm, 1.4mm OD x 3mm long ceramic ferrule on the end
12294	HSMJ-3S-1300/1550-9/125-1-X-25-25-0.5-2.5KO	0.5 meter long, 1mm OD jacketed 1300/1550nm 9/125um Corning SMF-28 fiber patchcord with a Super FC/PC connector on one end, metal soldered tip on the other end. Protruding fiber length is 25mm, metalized fiber length is 25mm, gold plated kovar OD is 2.5mm, no ferrule or cleave on the end
7839	HSMJ-X-1300/1550-9/125-1-X-27-16.47-1.9-2.5KO	1.9 meter long, 1mm OD jacketed 1300/1550nm Corning 9/125um SMF-28 fiber patchcord with no connector on one end, metal soldered tip on the other end. Protruding fiber length is 27mm, metalized fiber length is 16.47mm, gold plated kovar OD is 2.5mm, no ferrule or cleave on the end
12604	HPMJ-3A-1550-8/125-1-C1.4-14-11-1-2.5KO	1 meter long, 1mm OD jacketed 1550nm 8/125um Polarization Maintaining fiber patchcord with an Angle FC/PC connector on one end, metal soldered tip on the other end. Protruding fiber length is 14mm, metalized fiber length is 11mm, gold plated kovar OD is 2.5mm, 1.4mm OD x 3mm long ceramic ferrule on the end

### Ordering Examples For Standard Parts:

A customer needs to hermetically seal a singlemode fiber into a package. The fiber will be aligned using a 1.4mm OD ceramic ferrule which needs to be approximately 14mm from the packaging port. The customer would also like the fiber to be 1 meter long with 900 micron jacketing and an angle FC/PC connector on the opposite end.

Bar Code	Part Number	Description
12595	HSMJ-3A-1300/1550-9/125-1-C1.4-14-11-1-2.5KO	1 meter long, 1mm OD jacketed 1300/1550nm 9/125um Corning SMF-28 fiber patchcord with an Angle FC/PC connector on one end, metal soldered tip on the other end. Protruding fiber length is 14mm, metalized fiber length is 11mm, gold plated kovar OD is 2.5mm, 1.4mm OD x 3mm long ceramic ferrule on the end

## Standard Product Specifications:

Helium Leak Rate	<10 <sup>-8</sup> ATM-cc/sec
Operating Temperature	-40°C to +85°C
Pull Strength	1 Kg minimum
Polarization Extinction Ratio	>20dB, 25dB, or 30dB available for 1300 – 1625nm
Metalization Materials/Thickness (Standard) <sup>1</sup>	Nickel: 1.5 to 2.0 microns thick base Gold: 0.15 to 0.20 microns thick overcoat
Maximum Plating Length	50mm
Plating Length Tolerance	±1mm
Recommended installation solder	60% Tin / 40% Lead
Recommended installation temperature	185°C-200°C

<sup>1</sup> Other materials and thicknesses available on request

## Ordering Information For Custom Parts:

OZ Optics welcomes the opportunity to provide custom designed products to meet your application needs. As with most manufacturers, customized products do take additional effort so please expect some differences in the pricing compared to our standard parts list. In particular, we will need additional time to prepare a comprehensive quotation, and lead times will be longer than normal. In most cases non-recurring engineering (NRE) charges, lot charges, and a 25 piece minimum order will be necessary. These points will be carefully explained in your quotation, so your decision will be as well informed as possible. We strongly recommend buying our standard products.

## Questionnaire For Custom Parts:

1. What type of fiber do you require for your applications (singlemode, multimode, PM)?
2. What is your operating wavelength?
3. Does the fiber need to be cabled?
4. How long should the patchcord be?
5. How long would you like the fiber to protrude from the end of the seal tube?
6. Does the metalization need to cover the entire fiber? If not, how long do you need (from the end) to be without metalization?
7. Do you need a ferrule (or puck) on the end of the metalized fiber?
8. Do you need a connector on the other end?
9. What type of feedthrough best serves your needs?
10. Do you have any special requirements?

## HFMJ-X-W-a/b-JD-YP-A-B-L-FT

**F** = Fiber Type  
M = Multimode  
S = Single Mode  
P = Polarization Maintaining

**X** = Connector Code  
3S = Super FC  
3U = Ultra FC  
3A = Angle FC  
8 = ST  
SC = Super SC  
SCU = Ultra SC  
SCA = Angle SC  
MU = Super MU  
LC = Super LC  
LCA = Angle LC  
X = No Connector

**W** = Wavelength, in nanometers  
1300/1550 for Corning SMF-28 Singlemode fiber

**a/b** = Fiber core/cladding  
9/125 for Corning SMF-28 singlemode fiber  
6/125 for Corning Flexcore1060 singlemode fiber  
7/125 for 1300nm PANDA style PM fiber  
8/125 for 1550nm PANDA style PM fiber

**JD** = Jacket Diameter  
0.25 = 250 micron acrylate coating (standard bare fiber)  
0.40 = 400 micron acrylate coating (PM bare fiber)  
1 = 900µm Hytrel loose tube buffered fiber (standard)

**FT** = Hermetic feedthrough design (See figures 10-13)  
2.5KO = Standard 2.5mm OD, gold plated kovar  
B2.5KO = "Bullet Nose" 2.5mm OD, gold plated kovar  
2.5SA = Standard 2.5mm OD, gold plated stainless alloy  
1.5KO = 1.53mm OD, gold plated kovar  
0.9KO = 0.9mm OD, gold plated kovar

**L** = Overall Length in Meters

**B** = Metalized fiber length in millimeters (for assemblies with ferrules, this number should match "A")

**A** = Protruding fiber length in millimeters

**P** = Angle polish for ferrules  
A for 8 degree angle polish.  
Leave blank for flat polish.  
Contact OZ for custom angle polishes

**Y** = Ferrule Type (see figures 4-9)  
C1.25 = Ceramic, 1.25mm dia.x7mm long  
C1.4 = Ceramic, 1.4mm dia.x3mm long  
C1.8 = Ceramic, 1.8mm dia.x10.5mm long  
C2 = Ceramic, 2mm dia.x10.5mm long  
C2.5 = Ceramic, 2.5mm dia.x10.5mm long  
R = Rectangular glass, 1.4x2.5x7.5mm  
0 = Flat (0 degree angle) cleave  
8 = 8 degree angle cleave  
X = Bare fiber, no ferrule or cleave

## Ordering Examples For Custom Parts

A customer needs to hermetically seal a PANDA style 1550nm PM fiber into a package. The fiber will be aligned using a 1.4mm diameter ferrule, angle polished, that needs to be approximately 25mm from the packaging port. The metalization will extend to the tip of the ferrule. The customer wants the 1.53mm OD feedthrough for small size packaging. The customer would also like the fiber to be 1 meter long with 900 micron jacketing and a Angle FC/PC connector on the opposite end.

Bar Code	Part Number	Description
12595	HSMJ-3A-1550-8/125-1-C1.4-25-25-1-1.5KO	1 meter long, 1mm OD jacketed 1550nm 8/125um Polarization Maintaining fiber patchcord with an Angle FC/PC connector on one end, metal soldered tip on the other end. Protruding fiber length is 25mm, metalized fiber length is 25mm, gold plated kovar OD is 1.53mm, angle polished 1.4mm OD x 3mm long ceramic ferrule on the end

### Frequently Asked Questions (FAQs):

**Q:** Is there a chance that I will break the hermetic seal on the fiber while soldering the assembly into my package?

**A:** The metal solder used to seal the fiber has a melting point of 220°C, which is higher than that of the standard package solder (60/40 Tin Lead, 184°C). Therefore if the proper soldering temperatures are used the seal will not be broken.

**Q:** What is the longest length of protruding metalized fiber that I can order?

**A:** The maximum length offered is 50mm

**Q:** If I am going to use a ferrule on the end of the hermetic patchcord should I specify a masked region?

**A:** It is recommended that full metalization be used for most applications requiring a ferrule. This will provide the best support for the fiber during handling and installation. A slightly larger ferrule hole diameter of 130 microns will be required for this application.

### Application Notes:

#### Soldering Hermetic Feedthroughs Into Optical Packages

Because hermetic feedthroughs are installed using solders, care must be taken not to overheat the feedthrough or the fiber. Applying too much heat can potentially damage the hermetic seal, the jacketing, or the fiber itself. To minimize the likelihood of damage, we recommend the following precautions:

- 1) Ensure that all surfaces are properly cleaned and prepared:** To ensure a good solder joint, we recommend that the part the feedthrough is being installed into should be plated with at least 5 microns of nickel, followed by 1.3 microns of gold. All parts should be cleaned using isopropyl alcohol prior to soldering, to ensure that there are no organic residues on the parts.
- 2) Do not apply excessive heat while soldering:** The solder used to seal the fiber to the feedthrough has a melting temperature of just over 220°C. In contrast, standard tin/lead solder has a melting point of 184°C. Consequently any soldering process used should not heat the seal tube more than 210°C. 185°C to 200°C is recommended for standard tin/lead solders. There are also special low temperature solders, which can be used to provide a greater safety margin.
- 3) Minimize the area being heated:** The acrylate coatings used on standard fibers is designed for operating temperatures up to 85°C. Heating the fiber to temperatures significantly beyond this can damage the coating material. In addition, hytel tubing, which is used as a protective loose tube buffer, has a softening temperature of 180C. Therefore care must be taken not to overheat the fiber.

To do so, one needs to use a soldering technique that only heats the package and the feedthrough at the point where the solder joint is being made. One option is to use a laser to apply heat at a precise point. Inductive heating is another useful, non-contact heating method. Eddy currents are generated locally by inducing voltage pulses in the feed-through tube. This in turn generates heat in the work pieces. Another approach is to use resistive heating. Current is applied across the area where the solder joint is being made. The current heats the pieces. The heat is concentrated in the area of greatest current. The current, temperature and time can all be precisely controlled. No matter what method is used, the time taken to actually make the solder joint should be kept to a minimum, ideally less than 10 seconds. Otherwise the surrounding parts will begin to be heated, including the fiber and jacketing.

- 4) Minimize the use of fluxes:** Although fluxes do improve the wetting of standard solders to metal surfaces, they are also a potential source of contamination. To best control the amount of flux being used, OZ Optics recommends using solder performs, with the flux already in the core of the perform. This ensures that only a controlled amount is being used, and that it is only applied to the region being soldered. Any excess flux should be wiped away immediately after the solder has cooled back to room temperature (typically less than one minute).

By keeping these handling practices in mind, one should be able to routinely install hermetic feedthroughs into your system with high yields and reliability.



## Proper Storage and Handling of Stripped or Metalized Fibers

Given that the protective acrylate coating is removed from the end of a fiber when it is metalized, certain precautions should be taken to ensure that the fiber will remain as strong as possible. This includes controlling the humidity, minimizing tensile stress, and minimizing handling of the bare glass.

**Humidity:** Humidity is not an issue unless the fiber is under some tensile stress. If there is stress, water from the air will find its way into the microscopic flaws in the glass and break the silica bonds, potentially leading to a fiber break years down the road. If there is no tensile stress, then this mechanism doesn't work. If the fiber will be placed under stress during subsequent processing steps and the fiber surface is either contaminated or has an effectively high moisture surface content from the air, then one can potentially cause a failure. It is good practice to store bare fiber (i.e. stripped or metalized fiber products) in a dry, controlled atmosphere or in nitrogen atmosphere.

**Handling:** With respect to mechanical reliability, once the protective coating has been removed, the bare glass is vulnerable to damage with any subsequent handling. Thus your production process should eliminate any handling of the bare glass on the stripped section. Also, one should design the product to minimize unnecessary contact with the bare glass.

**Fatigue resistance and maintaining fiber reliability:** In general do not subject the fiber to stress higher than 50% of the proof stress for longer than 1 second, or 1/3 of proof test for longer than 4hrs. (i.e. 100kps = 50kpsi for 1 second). Also for fiber patchcords do not bend the fiber too tightly. For 100kpsi fiber do not bend any tighter than a 13mm bend radius. For 200kpsi do not bend the fiber any tighter than a 6.5mm bend radius.

**Cleaning:** Use Isopropyl Alcohol (IPA) with a lint free open mesh cloth. Perform a single wipe only. Never use Acetone to clean.

## Application Example: Laser Diode With Integrated Power Monitor:

Laser diodes built using hermetic patchcords can now be built with inline optical taps installed directly inside the package to monitor the output signal intensity. This provides a more precise means of monitoring the signal intensity, as signal seen by the directional tap is not influenced by return losses from the fiber output, which otherwise would be seen in conventional laser diode modules.

