



HIGH POWER FREE SPACE AND FIBER PIGTAILED ISOLATORS

Preliminary

Features:

- Reliable high power handling: As much as 80Watts;
- High Isolation, up to 50dB isolation possible from a single stage
- Low Insertion losses
- Low polarization dependent losses
- Compact size, low cost
- Wide Spectral Range: 60nm operating wavelength range.
- Large Clear Aperture: 5mm diameter clear aperture, for beams up to 1.2mm in diameter
- Excellent Beam Quality: <1 mrad divergence, typically M² factor of 1.2 with standard fiber
- Easily mountable options for fiber collimators and beam expanders
- Superior design with removable protective windows
- Pigtail or adjustable focus receptacle style collimators/focusers for fiber to free space versions

Applications:

Protection of high power lasers from back reflections during:

- Laser marking and engraving
- Laser cutting and etching of metal surfaces with high reflectance such as Aluminum, Copper, Gold or Silver.
- Micro Machining and Trimming

Introduction:

Isolators are optical devices that allow light to be transmitted in one direction only. They are most often used to prevent any reflected light from entering the source, thus preventing any feedback problems, such as frequency instability, relaxation oscillations, amplified stimulated emissions, or optical damage from occurring.

With the recent dramatic increase in laser output powers, especially in the 1040-1090nm wavelength range, the need to prevent the negative effects of optical feedback into lasers has become critical.

To meet this demand OZ Optics has developed a line of high power handling polarization independent isolators, capable of peak isolation levels of 30 to 50dB for 1040 to 1090nm, depending on the input beam size. The isolators are offered with fiber pigtailed collimators on the input beam, with typical beam diameters of 0.8 to 1.1mm.

Product Description:

OZ Optics uses a patented tilt alignment technique to manufacture isolators with fiber pigtails. Light from an optical fiber is first collimated then transmitted through the isolator. If desired, a similar fiber pigtailed collimator can be mounted on the output end of the isolator for a fiber pigtailed isolator. The fibers can be standard single mode fibers or Large Mode Area (LMA) fibers. LMA fibers are used to reduce the optical power density in the fiber core and therefore allow guidance of larger input power levels while still achieving near-gaussian output beam quality.

This patented tilt alignment technique allows OZ Optics to offer compact pigtailed devices, with footprints of 48mm x 86mm or 32mm diameter x 82mm long. In addition the isolators come with built-in windows to prevent dust contamination of internal isolator optics. These protection windows are easily removed and installed by the user

OZ Optics also offers receptacle style fiber to free-space isolators as shown in Figure 3, where customers can connect a high power patchcord terminated with an adjustable FC connector as shown in Figure 4. This option gives the user extra flexibility in the control of beam size propagating through the isolator.



Premium Grade High Power Free Space Isolator



Premium Grade Fiber Pigtailed Collimator to Free Space 1064nm Isolator



Standard Grade Fiber Pigtailed High Power Isolator with Beam Expander



Standard Grade Fiber to Fiber High Power Isolator with Adjustable FC/PC Patchcord and Receptacle at Output End

Polarization insensitive isolators use birefringent crystals to separate the input beam into two orthogonal polarizations, transmit them through the Faraday crystal and then recombine them to produce an output beam.

For maximum transmission, low absorption and high isolation, careful alignment of the internal components with respect to the propagating optical beam is needed. We offer Premium Grade and Standard Grade versions. The key specifications for these two versions are summarized in Tables 1 and 2.

Fiber Optic Isolator Product Specifications:

Table 1: Premium Grade 1064nm High Power Free Space Isolator Specifications¹

Parameter	Min.	Typ.	Max.	Condition
Operating wavelength (nm)	1040		1090	At 25°C
Operating temperature (°C)	10-60°C			At 1064nm
Power handling (W)	30	50	80	At 1064nm, @ 25°C
Insertion loss (dB)		0.3	0.5	At 1064nm, @ 25°C
Isolation (dB)	35	40	50	At 1064nm, @ 25°C
Isolation over temperature range (dB)	21			At 1064nm over 10-50°C
PDL (dB)		0.1	0.2	
Nominal beam diameter ⁽²⁾ (mm)	0.8	1.0	1.2	
Beam M ² factor		1.1	1.2	With single mode input fiber
Beam divergence (mrad)			1	Full angle, using singlemode input fiber
Pointing accuracy (mrad)			1	With singlemode input fiber
Beam expander magnification	Various magnifications available upon request			Depending on type of input fiber used
Package size ⁽³⁾ (mm)	48mm(W)x48mm(H)x133mm(L)			Reference Figure 5

Note 1: Other wavelengths available on request. Contact OZ Optics for detailed specifications.

Note 2: Other beam diameters available on request.

Note 3: Due to ongoing design improvements, the package size is subject to change. Please contact OZ Optics for confirmation.

Table 2: Standard Grade 1064nm High Power Free Space Isolator Specifications¹

Parameter	Min.	Typ.	Max.	Condition
Operating Wavelength (nm)	1050		1080	At 25°C
Operating temperature (°C)	10-60°C			At 1064nm
Power handling (W)	15	25	35	At 1064nm, @ 25°C
Insertion loss (dB)		0.4	0.6	At 1064nm, @ 25°C
Isolation (dB)	30	35	45	At 1064nm, @ 25°C
Isolation over temperature range (dB)	21			At 1064nm over 10-50°C
PDL (dB)		0.1	0.2	
Nominal Beam diameter ⁽²⁾ (mm)	0.5	0.8	1.0	
Beam M ² factor		1.1	1.2	With single mode input fiber
Beam divergence (mrad)			1	Full angle, using singlemode input fiber
Pointing accuracy (mrad)			1	With singlemode input fiber
Beam expander magnification	Various magnifications available upon request			Depending on type of input fiber used
Package size ⁽³⁾ (mm)	35(Φ)x78mm(L)			Reference Figure 6

Note 1: Other wavelengths available on request. Contact OZ Optics for detailed specifications.

Note 2: Other beam diameters available on request.

Note 3: Due to ongoing design improvements, the package size is subject to change. Please contact OZ Optics for confirmation.

OZ Optics can provide these isolators as free-space versions with options for the customer to mount the fiber pigtailed collimator or beam expander at the customer's site. The OZ Optics tilt adjustment technique affords well for customers to perform the optical alignment themselves.

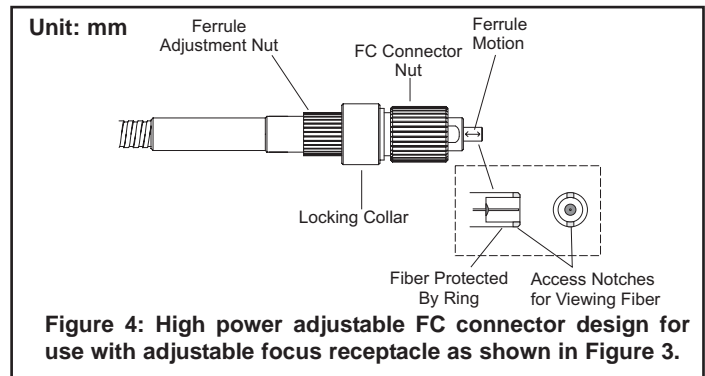
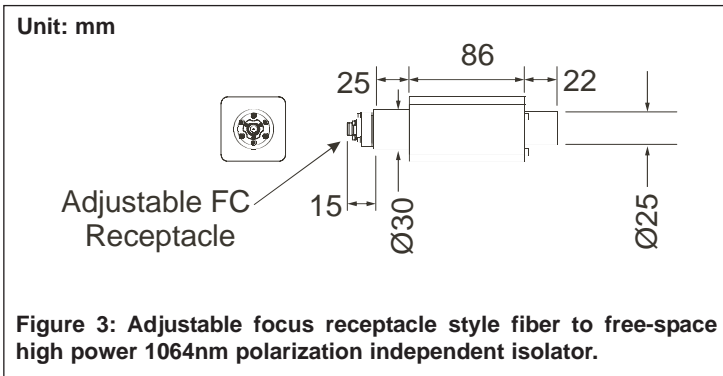

Package Dimensions:

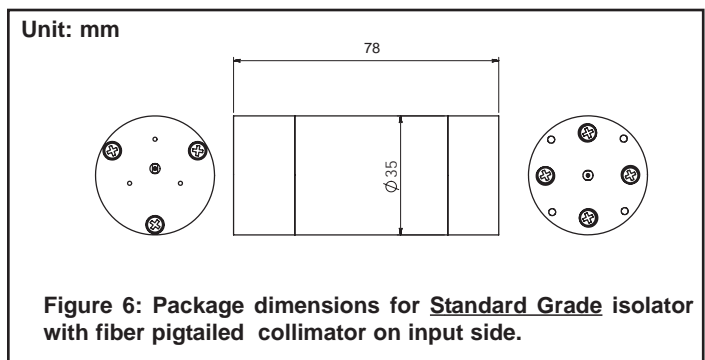
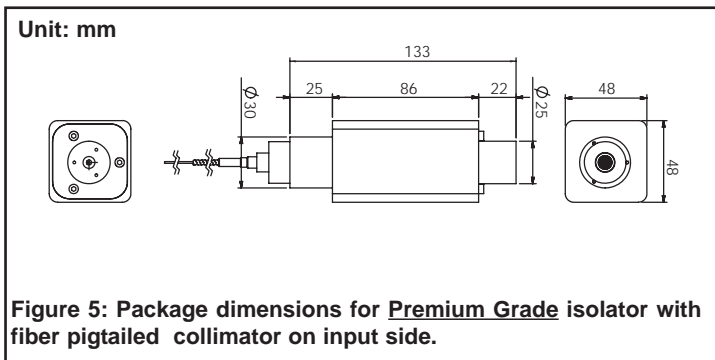

Ordering Information:

Questionnaire

Please answer the following questions, so we can quote you the best isolator for your application. For custom parts, please contact OZ Optics.

1. What is your input power level?
2. What is the center wavelength of your source?
3. Do you need a free-space isolator, a fiber-to-air isolator or a fiber pigtailed isolator?
4. Do you need a Premium Grade or a Standard Grade isolator?
5. If free-space type, what is your input beam diameter?
6. If the fiber-to-air type, what type of input fiber do you require: Standard singlemode, polarization maintaining, or LMA fiber. If LMA, please supply fiber specifications -fiber manufacturer's datasheet if possible, core/cladding size, and core & cladding numerical aperture value at the least.
7. For fiber collimator pigtail, do you need 3mm or 5mm OD armor cabled fiber?
8. Do you need a beam expander assembly at the output? If so, what is the required collimated beam diameter?
9. Do you need a connector on the free end of the fiber pigtailed collimator? Please note that in general power handling capability of connectors may not be high as the isolator. For example, we recommend that connectors are only used to facilitate testing of device at low power levels and that fiber is directly fusion spliced to the fiber laser source.

Description

Part Number

Free Space Isolator:

***F*OPI-00-*W*-*CA*-*I*-*HP*(*Y*)**

W = Wavelength in nm

CA = Clear aperture (mm)
5mm standard

Y = CW Power handling in Watts

I = Peak isolation in dB
40dB: Premium grade
30 dB: Standard grade

Description

Part Number

Fiber Pigtailed Collimator
to Free Space Isolator:

***F*OPI-10-*W*-*a/b*-*F*-*BD*-*f*-*BL*-*X*-*JD*-*L*-*I*-*HP*(*Y*)-*BE*(*M*)**

W = Wavelength in nm

a/b = Fiber core and cladding diameters, in
microns: (Example: 6/125 for 1064 nm)

F = Fiber Type: S = Singlemode
P = Polarization maintaining
LMA = Large Mode Area

BD = Beam Diameter, in mm
Typically 1mm

f = Lens focal length and type: (OZ Optics will
choose lens type appropriate for power level and
beam size)

BL = Backreflection level:
40, 50 dB for 1064 nm

BE = Beam Expander
M = Magnification
M = 1 is no beam expander

Y = CW Power handling in Watts

I = Peak isolation in dB
40dB: Premium grade
30dB: Standard grade

L = Fiber length in meters

JD = Jacket Diameter
3AS = 3mm OD stainless steel armored
5AS = 5mm OD stainless steel armored
See table 7 of the standard tables for drawings

X = Connector code:
X = No connector
3S = Super NTT-FC/PC
3A = Angled NTT-FC/PC

See table 6 of the OZ Standard Tables data
sheet for information on connectors.

Note: In some cases standard connectors may
not work for the desired power handling.
Connectors are offered for testing at low
powers only. For use at high power levels,
please cut off the connector and fusion splice to
the laser source.

Description

Part Number

Receptacle Style Fiber to :
Free Space Isolator

***F*OPI-*X*0-*W*-*F*-*f*-*I*-*HP*(*Y*)**

X = Input side Receptacle code
3 for super FC/PC or ultra FC/PC
A3 for adjustable flat FC/PC

Note: Adjustable FC receptacle must be used
with a patchcord terminated with adjustable
connector as shown in Figure 4.

W = Wavelength in nm

F = Fiber Type: S = Singlemode
P = Polarization maintaining
LMA = Large Mode Area

Y = CW Power handling in Watts

I = Peak isolation in dB
40dB: Premium grade
30 dB: Standard grade

f = Lens focal length in mm and type (OZ
Optics will select)

Description

Part Number

Fiber to Fiber Pigtailed Isolator:

FOPI-11-11-W-a/b-F-BL-XY-JD-L-I-HP(Y)

W= Wavelength in nm

a/b = Fiber core and cladding diameters, in microns: (Example: 6/125 for 1064 nm)

F = Fiber Type: S = Singlemode
P = Polarization maintaining
LMA: Large Mode Area

BL = Backreflection level:
40, 50 dB for 1064 nm

Y = CW Power handling in Watts

Note: >10W power handling only available for LMA fibers

I = Peak isolation in dB
40dB: Premium grade
30dB: Standard grade

L = Fiber length in meters

JD = Jacket Diameter
3AS = 3mm OD stainless steel armored
5AS = 5mm OD stainless steel armored
See table 7 of the standard tables for drawings

X,Y = Connector code:

X = No connector

3S = Super NTT-FC/PC

3A = Angled NTT-FC/PC

See table 6 of the OZ Standard Tables data sheet for information on connectors.

Note: In some cases standard connectors may not work for the desired power handling. Connectors are offered for testing at low powers only. For use at high power levels, please cut off the connector and fusion splice to the laser source.

Part Number Example For Fiber Pigtailed Collimator to Free-Space Isolator:

Part Number: FOPI-10-1064-25/250-LMA-0.8-6.2AS-50-X-3AS-1-30-HP20-1

Description:

Fiber to Free-space beam 1064nm Polarization independent 20W power handling isolator: Input side consists of a pigtail style collimator for 1064nm with 1 meter long, 3mm OD stainless steel cabled 25/250µm LMA passive singlemode fiber, with core NA=0.065 with a f=6.2mm aspheric lens and 50dB return loss. The output beam diameter will be about 0.8mm with a beam divergence of approximately 4mrads. The isolator will transmit light entering the fiber and the collimator assembly, and block light entering from the free-space beam output side. The peak isolation level is approximately 30dB (21dB minimum). HP20: High Power Application for up to 20 Watt average power handling (1.5mJ@100ns, 20kW peak power). M=1: Without beam expander.