



## ELECTRICALLY DRIVEN POLARIZATION CONTROLLER-SCRAMBLER

### Features:

- Negligible insertion losses
- Negligible return losses
- Negligible Polarization Dependent Losses (PDL)
- >100Hz response speed
- Continuous polarization control capability
- Low voltage

### Applications:

- Polarization scrambling
- Polarization stabilization
- Polarization Mode Dispersion (PMD) mitigation
- Polarization Dependent Loss (PDL) mitigation
- PDL and PMD Measurement Systems
- Interferometers and Sensors

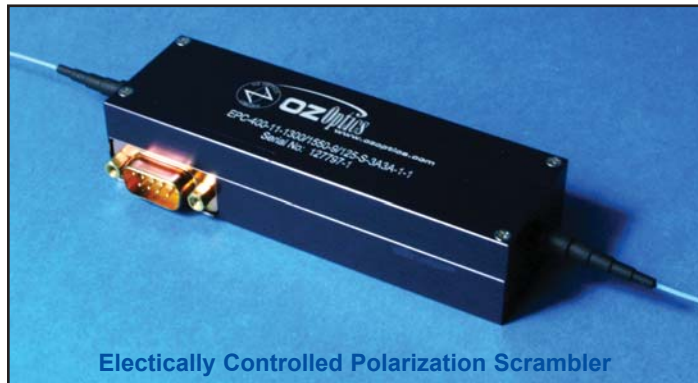

Electrically Controlled Polarization Scrambler

### Product Description:

OZ Optics' Electrically Driven Polarization Controller (EPC) provides a simple, efficient means to manipulate the state of polarization within a singlemode fiber. Employing a novel mechanical fiber squeezing technique, the device is controlled by either three or four (depending on the model) input voltages that one varies over a  $\pm 5$  volt range to provide endless polarization control in a robust, easy to operate package. The controller's rapid response speed easily handles changes in polarization caused by the external environment, and is highly suitable for polarization scrambling for either averaging PDL effects, or for making PMD or PDL measurements. Because the fiber within the device is continuous, all insertion losses, return losses, and PDL effects are limited only by the fiber itself. This makes it ideal for precise test and measurement applications.

The polarization controller is available in either a three or four channel configuration. The three channel system is ideal for polarization scrambling applications such as for polarization averaging or PDL measurements. The added redundancy of the four channel version opens the way to continuous polarization control, without having to occasionally reset the device when a controller reaches its limit.

The unique design of the OZ Optics Polarization Controller means that it does not require any dedicated driver circuitry. There are no internal voltage multipliers or high voltage signals to worry about. Thus operation is safe and simple.

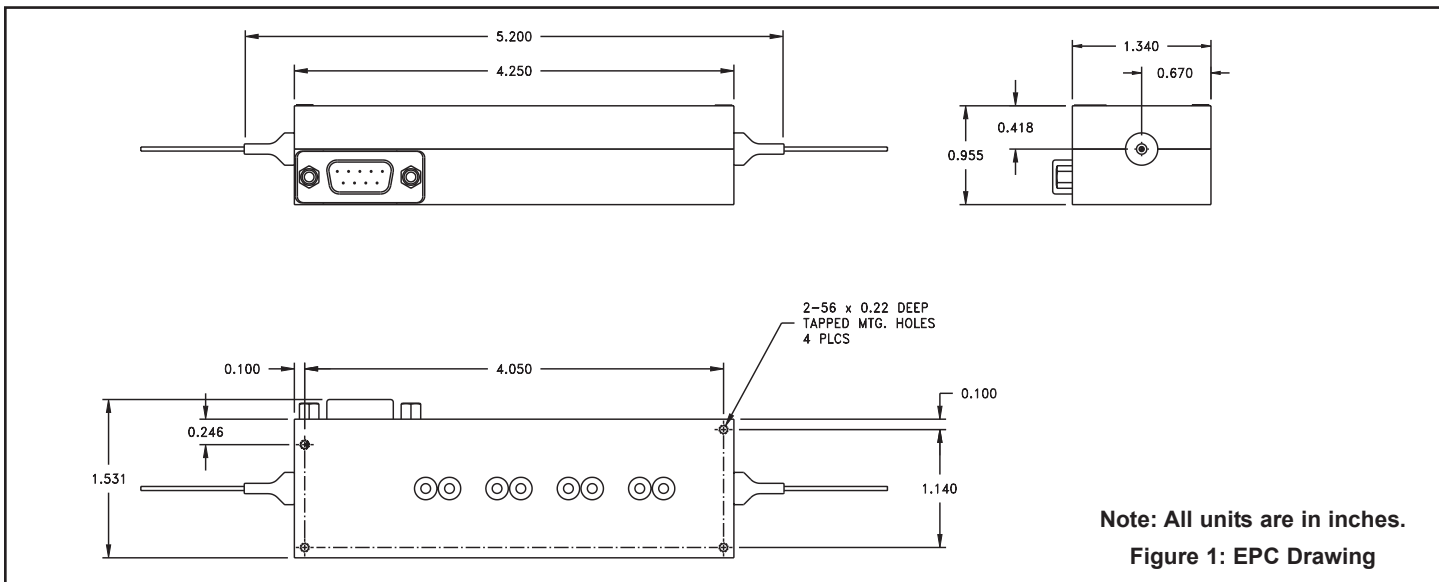

## Standard Product Specifications:

Model	EPC-300	EPC-400
<b>Electrical</b>		
Number of Control Channels	3	4
Voltage Range	±5 Volts	
3dB Bandwidth	100 Hz	
Recommended Scrambling Frequencies (Hz)	6, 11, 31 and 71	
Power Consumption	0.5 Watts per channel (Max.)	
Electrical Interface <sup>1</sup>	DB-9	
<b>Optical</b>		
Retardation Range	2 $\pi$ Minimum	
Insertion Loss not including connectors <sup>2</sup>	< 0.4 dB	
Backreflection	>70dB excluding connectors	
Wavelength Range	1250 to 1650 nm Standard — Other wavelengths available on request	
Activation Loss <sup>3</sup>	± 0.03 dB	
Polarization Dependent Loss (PDL)	<0.06 dB	
Operating Temperature	-10°C to +50°C	
Storage Temperature	-40°C to +80°C	
Fiber Type	Corning SMF-28 Standard — Other fiber types available on request	
<b>Mechanical</b>		
Dimensions (LxWxH)	150x44x35 mm	
Weight	400 grams	

<sup>1</sup> Other types of electrical interfaces like 5-pin headers or BNC are available upon request.

<sup>2</sup> When connectorized with FC/UPC connector IL < 1 dB.

<sup>3</sup> With -5V to +5V applied to each channel.

## Ordering Information For Standard Parts:

Bar Code	Part Number	Description
20055	EPC-300-11-1300/1550-9/125-S-3A3A-1-1	Three Channel Polarization Scrambler using standard Corning SMF-28 singlemode fiber. The input and output fibers are one meter long, with 900 micron diameter loose tube jacketing, terminated with angled FC/APC connectors.
22244	EPC-300-11-1300/1550-9/125-S-XX-1-1	Three Channel Polarization Scrambler using standard Corning SMF-28 singlemode fiber. The input and output fibers are one meter long, with 900 micron diameter loose tube jacketing, terminated with no connectors.
13615	EPC-300-11-1300/1550-9/125-S-3U3U-1-1	Three Channel Polarization Scrambler using standard Corning SMF-28 singlemode fiber. The input and output fibers are one meter long, with 900 micron diameter loose tube jacketing, terminated with Ultra FC/PC connectors.
15524	EPC-400-11-1300/1550-9/125-S-3A3A-1-1	Four Channel Polarization Controller with Corning SMF-28 singlemode fiber. Input and output one meter long with 900 micron OD jacket terminated with angled FC/APC connectors
15516	EPC-400-11-1300/1550-9/125-S-SCASCA-1-1	Four Channel Polarization Controller with Corning SMF-28 singlemode fiber. Input and output one meter long with 900 microns OD jacket terminated with angled SC connectors
16360	EPC-400-11-1300/1550-9/125-S-SCUSCU-1-1	Four Channel Polarization Controller using standard Corning SMF-28 singlemode fiber. The input and output fibers are one meter long, with 900 micron diameter loose tube jacketing, terminated with Ultra SC connectors.
13616	EPC-400-11-1300/1550-9/125-S-3U3U-1-1	Four Channel Polarization Controller using standard Corning SMF-28 singlemode fiber. The input and output fibers are one meter long, with 900 micron diameter loose tube jacketing, terminated with Ultra FC/PC connectors.
15952	EPC-DRIVER-04	4 Channel EPC Driver/Controller Box featuring a dual mode operation: controller mode and scrambler mode. DC voltage ranging from -5 to +5V, frequency settable from 1 to 100 Hz, and maximum current of 100 mA per channel.
16361	EPC-DRIVER-04-RS/232	4 Channel EPC Driver/Controller Box featuring a dual mode operation: controller mode and scrambler mode. DC voltage ranging from -5 to +5V, frequency settable from 1 to 100 Hz, and maximum current of 100 mA per channel. Built-in RS-232 provided.

## Ordering Example For Standard Parts:

A customer is building a polarization scrambler circuit for PDL testing at 1550 nm. He will use a three stage system with standard singlemode fiber, and FC connectors.

Bar Code	Part Number	Description
13615	EPC-300-11-1300/1550-9/125-S-3U3U-1-1	Three Channel Polarization Scrambler using standard Corning SMF-28 singlemode fiber. The input and output fibers are one meter long, with 900 micron diameter loose tube jacketing, terminated with Ultra FC/PC connectors.

## Ordering Information For Custom Parts:

OZ Optics provides custom designed products to meet your application needs. As with most manufacturers, customized products do take additional effort so please expect some differences in the pricing compared to our standard parts list. In particular, we will need additional time to prepare a comprehensive quotation, and lead times will be longer than normal. In most cases non-recurring engineering (NRE) charges, lot charges, and a one piece minimum order will be necessary. These points will be carefully explained in your quotation, so your decision will be as well-informed as possible. We strongly recommend buying our standard products.

### DESCRIPTION

### PART NUMBER

#### Controller and Scrambling Unit **EPC-A-11-W-a/b-S-XY-JD-L-(C)**

**A** = 300 for 3 stage scrambler  
400 for 4 stage controller

**W** = Wavelength: Specify in nanometers:  
Example: 1300/1550 for standard telecom wavelength range

**a/b** = Fiber core/cladding sizes, in microns  
9/125 for Corning SMF-28 Singlemode fiber. See standard tables for other standard fiber sizes

**XY** = Connector code:  
X = No Connector  
3S = Super NTT-FC/PC  
3U = Ultra NTT-FC/PC  
3A = Angled NTT-FC/PC  
8 = AT&T-ST

SC = SC  
SCU = Ultra SC  
SCA = Angled SC  
LC = LC/PC  
See standard tables for other connectors

**(C)** = Electrical interface connector  
Leave blank for DB-9  
PH = 5-pin header  
BNC = Female BNC

**L** = Fiber Length in meters, on each side of the device. If they are different lengths, specify the input and output lengths separated by a comma. Example: To order 1 meter of the fiber at the input and 7 meters at the output, replace L with 1,7.

**JD** = Fiber jacket type:  
1=900 micron OD hytel jacket

## Questionnaire For Custom Parts:

- Are you performing polarization scrambling or polarization controlling?
- What is your operating wavelength?
- What type and size of fiber do you want?
- What type of connectors do you need?
- How long should the fibers be?
- What is the fiber jacket OD?
- What type of electrical interface do you need?

## Ordering Example For Custom Parts:

A customer wants a 4-channel polarization controller for 1310 nm wavelength. He wants singlemode fibers, 1 meter long, 900 micron hytel jacketing with FC/APC connectors and a 5-pin header electrical interface. He also wants an EPC driver with built-in RS232 for remote control. He needs to order the following part numbers:

Bar Code	Part Number	Description
n/a	EPC-400-11-1300/1550-9/125-S-3A3A-1-1-PH5	Four Channel Polarization Controllers with Corning SMF-28 singlemode fiber. Input and output are 1 m long with 900 micron OD jacket terminated with angled FC connectors.
16361	EPC-DRIVER-04-RS/232	4 Channel EPC Driver/Controller Box featuring a dual mode operation: controller mode and scrambler mode. DC voltage ranging from -5 to +5V, frequency settable from 1 to 100 Hz and maximum current of 100 mA per channel. Built-in RS-232 provided.

## Application Notes:

**Example Application:** Polarization mode dispersion (PMD) is an important issue in the quest to build high speed (10Gbs, 40Gbs, and higher) communication networks. An input signal travelling along a single mode fiber normally has some distortion, due to polarization mode dispersion. The signal effectively has been split into two arbitrary, yet orthogonal polarizations, and one polarization is leading the other. A differential delay line is a crucial element to PMD compensation.

The figure below shows how to use a polarization controller to compensate for polarization mode dispersion. The controller is installed just before a differential delay line to convert the arbitrary polarizations from the input fiber into polarizations corresponding to the orthogonal polarization controlled by the differential delay line. The faster polarization is slowed down by the delay line and the combined signals then enter the output fiber to go to the receiver. A control system monitors the quality of the signal at the receiver, and dynamically adjusts the polarization and the delay to get the two signals to match up again. Thus the PMD in the system can be corrected in real time.

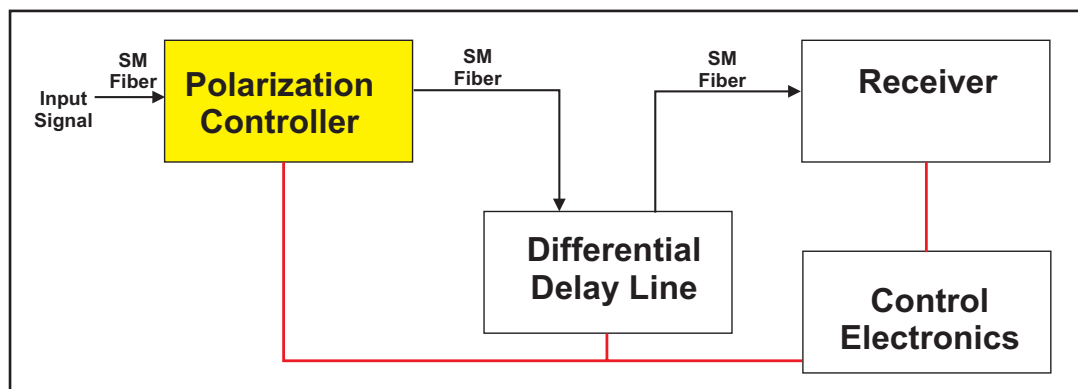

## Frequently Asked Questions (FAQ):

**Q:** How does the polarization controller/scrambler work?

**A:** The controller uses a unique, magnetically driven, fiber squeezer technique. By employing mechanical amplification, over 25N of force can be applied to a fiber. This is sufficient pressure to introduce a phase change in the polarization over 360 degrees in scale. By using three such squeezers, each at a 45 degree offset to its neighbour, one can show that one can convert any input polarization through the device into any desired output polarization.

**Q:** What is the advantage of your fiber squeezer system over other polarization controllers?

**A:** Other polarization controllers that make use of a squeezing technique typically use piezoelectric actuators. These actuators require voltages of over 150V in order to operate. Aside from the safety issues, it often takes specialized driver circuitry to produce such voltages. In contrast the OZ Optics polarization controller uses only a  $\pm 5V$  signal to achieve the same degree of control.

**Q:** Why do you recommend a four squeezer system over a three squeezer system for polarization controllers?

**A:** Four squeezers are recommended for continuous polarization control. While a three squeezer system is sufficient to convert any input polarization to any output polarization, it won't allow continuous control. If you are actively controlling the squeezers to maintain a constant polarization, you can drive one of the squeezers to its voltage limit. In a three squeezer system you would have no choice but to reset that squeezer, causing a temporary loss of the polarization. In a four squeezer system we have a redundant squeezer. One can reduce the voltage applied to the squeezer currently at its limit, and compensate for the change with the other three.

**Q:** Is a 100Hz response time fast enough?

**A:** Yes it is. Polarization effects occur over time spans of tens of milliseconds, with most variations occurring as gradual drifting, usually due to thermal effects, or low level seismic activity. The 100Hz response speed of the polarization controller is easily able to track such changes. For polarization scrambling applications, over 2000 polarization points were generated over a one second time frame, randomly scattered over the entire Poincare sphere.

**Q:** Can you make a controller with multimode fiber? How about with polarization maintaining fiber?

**A:** Building a polarization controller with multimode fiber would not make much sense. By definition, light within a multimode fiber can travel along several modes. Each mode will exhibit its own polarization state. It is impossible to control each mode individually. On the other hand, while the technique used in the polarization controller would not work on polarization maintaining fiber, one can attach a polarization maintaining fiber to the output of a polarization controller. One common application is to use the controller to take input light with changing polarization and convert it to linearly polarized light aligned to the slow or fast axis of the polarization maintaining fiber. This allows one to use sources that do not maintain polarization with polarization maintaining fiber.