



OZ Optics

www.ozoptics.com

219 Westbrook Rd, Ottawa, ON, Canada, K0A 1L0 Toll Free: 1-800-361-5415 Tel:(613) 831-0981 Fax:(613) 836-5089 E-mail: sales@ozoptics.com



FREE SPACE ULTRA STABLE LASER MODULE OZ 5000 SERIES

Features

- Output powers to 300 mW
- Wavelengths from 375 nm to 1625 nm available
- Excellent power & wavelength stability
- Low RMS noise
- Excellent beam pointing stability
- Electrically or optically variable output power
- Compact size, 101 x 50 x 38 mm
- Easily configurable analog interface
- Optional USB interface; other interfaces are also available
- Variable beam size: collimated or adjustable
- Guaranteed lifetime: 18 months or 5000 hours. Extended warranty is also available
- Low cost

Applications

- Confocal Microscopy
- Flow Cytometry
- DNA Sequencing
- Medical Imaging
- Interferometry
- Particle counting
- Printing
- Optical component manufacturing and testing
- Materials evaluation and testing



Free Space OZ-5000 Laser Modules

Preliminary

Product Description:

OZ-5000 laser modules are temperature stabilized, free space, laser diode delivery systems. The compact housings contain both the laser diode and the temperature control, and are powered by a single 5 volt DC supply. Both designs have an operating temperature range of 10 - 45°C, and hold the temperature variation of the laser diode to within less than 0.01°C. This maintains the wavelength variation to better than 0.1nm and also reduces the tendency of the laser diode to mode hop. OZ-5000 modules have standard analog and optional TTL interfaces for OEM applications, and an optional USB computer interface upon request.

The units are equipped with an adjustable output power feature. The output power can be adjusted by simply changing the DC voltage on the Power Control Input. The voltage range is 0 - 5 Volts, with 0 Volts corresponding to maximum power, and 5 Volts minimum power.

Most standard parts can be analog modulated at up to 100 kHz. Special versions are available from OZ Optics to cover even higher modulation frequencies, up to 155MHz. Contact OZ Optics with your requirements.

An interlock feature is also standard. This enables the user to shut the unit down if a safety issue or other error condition arises. This feature can also be used as a TTL on/off control. In addition, a mechanical shutter option is available for additional safety.

The OZ-5000 units also come with a 5000-hour/18 month warranty for wavelengths longer than 600nm. For wavelengths less than 600nm the manufacturer's warranty for the laser diode will apply.

Standard Product Specifications:

Optical Performance

AVAILABLE WAVELENGTHS ¹ (nm)																		
Wavelength (nm)	375	405	440	473	488	532	635	660	685	780	830	850	980	1060	1310	1490 ²	1550	1625
Standard Output Power (mW)	20	10 30 60 120	50	20	10 20	10 50	5 10 20 50 100	35 50 120	35	5 50 80	40 150	5 20 30	50	50	5	30	5	30
Long-term Power Stability ³	<3%					<5%	<1%					<1%						
Short-term Power Stability ³	Typically <0.5% Better stability available as an option						<0.5%					<0.5%						
Polarization Extinction ratio	Typically >20 dB																	
Wavelength Stability ⁴	Typically ± 0.1nm																	
RMS Noise (20 Hz- 20 MHz)	< 0.2% (diode laser) < 0.5% (green laser)																	
Peak to Peak Noise (20 Hz- 20 MHz)	< 0.75% (diode laser) < 5% (green laser)																	
Beam Divergence	< 1mrad																	
M-squared (M2)	<1.3																	
Beam Shape	Elliptical(Circular Beam available upon request)																	
Beam Size	1mm																	
Pointing stability	± 25 mrad																	

¹ These are standard center wavelengths. Typical tolerances vary from ± 5nm to ±30nm depending on laser diode manufacturer. Contact OZ Optics if a specific wavelength is required.

² Other available CWDM wavelengths are: 1430, 1450nm, 1470nm, 1510nm, and 1530nm

³ Depends on source wavelength, power level and other options. Refers to typical values achieved over a period of 24 hours for the long-term case and 1 minute for the short-term case after 15 minutes warm up time. This is for low power modules that are operated with no bias on analog power control pin.

⁴ Based on thermal stability achieved with TEC controller. Assumes absence of mode-hopping

Electrical Specifications

Power supply	5VDC
Operating Current	Typically <1.2 A for standard product, 4 A for high power
Power Consumption	<6 W typical
Warm up time	<1 min
Analog/TTL Control Interface	Via 9 pin DIN connector, see pin configuration.
Computer interface	USB (optional)
Power control	0 to 5 V (100% - 1%)
Analog Modulation	100 kHz
TTL Modulation	155 MHz(optional)

Analog/TTL interface 9 pin DIN connector pin out

1	Input	5VDC
2	Input	GND
3	Input	Laser ON/OFF control
4	Input	Power control (analog modulation)
5	Output	Laser status (confirm laser is working)
6	Output	Read laser current
7	Output	Read laser monitor current
8	Output	Fault status (Temp fault , over current)
9	Output	Temperature locked

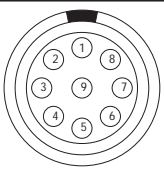

USB Computer interface functions

1	Set the temperature (Factory preset)
2	Set the laser power (Factory preset)
3	Set the current limit (Factory preset)
4	Read the operating time
5	Laser ON/OFF
6	Laser power control (0 to 100%)
7	Laser status
8	Read laser current
9	Read laser monitor current
10	Fault status (Temp fault, laser over current)
11	Temperature locked

Mechanical and Environmental Specifications

Dimensions	101.6 x 50 x 38 mm (4 x 2 x 1.5 inch)
Operating Temperature	10 to 45 °C
Operating Humidity	0-95% Non-condensing
Storage temperature	0-50°C

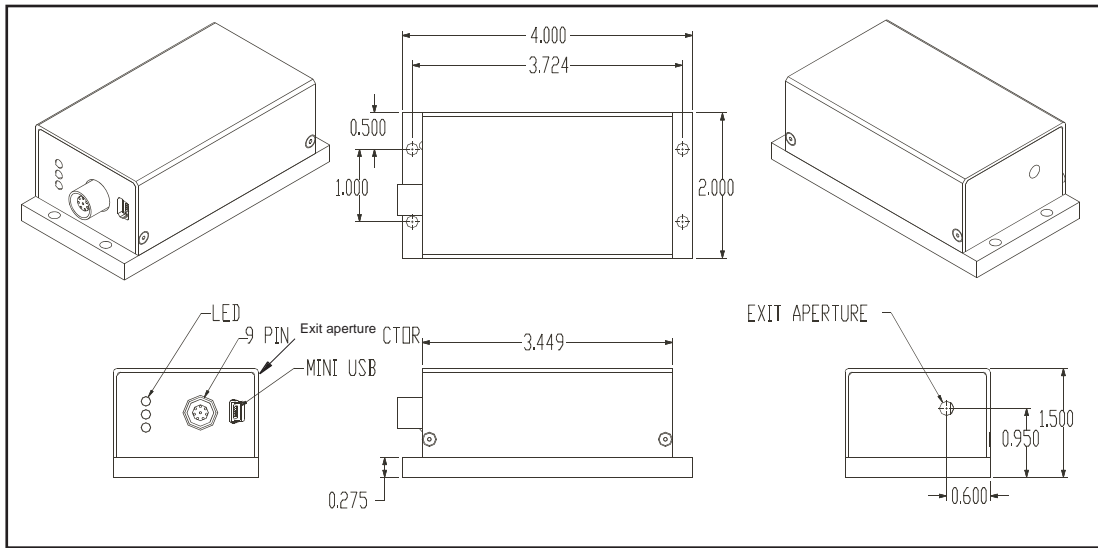

Figure 1: OZ-5000

Warranty And Lifetime

18 months or 5000 hours, whichever comes first when operated under the environmental conditions as stated above. Not applicable for wavelengths less than 600nm, for which the manufacturer's warranty for appropriate laser diodes will apply. Please consult OZ Optics for extended warranty for up to 5 years.

Laser Eye Safety

Warning: Up to class 4 product. Read and follow the appropriate laser safety warnings. Avoid direct exposure to the eyes and implement a level of laser safety that is appropriate for this class of laser as serious injury can result from improper use.

Questionnaire

1. What wavelength do you need?
2. How much output power do you need?
3. Do you need a collimated output beam?
4. If a collimated beam is required, what is the desired beam diameter?
5. If a focused spot is required, what is the desired spot size and working distance?

Description

OZ 5000 - Free Space Ultra Stable Laser Module

Part Number

OZ- 5000-W-P- BD

W Wavelength (nm) ¹:
375, 405, 440, 473, 488, 532, 635,
660, 685, 780, 830, 850, 980, 1060,
1310, 1490, 1550, 1625.

BD Beam diameter (mm):
1: Standard collimated 1 mm beam.
Contact OZ Optics for other beam diameters.

P Output power (mW) ²:
See the product specifications for
available powers.

¹ These are standard center wavelength values. The tolerance may vary depending on both wavelength and the laser diode manufacturers tolerance. (A typical tolerance varies from ± 5 nm to as high as ± 30 nm).

² Note that due to variations in the optical characteristics of the laser diodes being used, not all output powers are available at every wavelength.

Options: Add "-TTL" for up to 155 MHz TTL modulation. Add "-CIR" for Circular beam. Add "-USB" for Computer interface.

Ordering Examples for Custom Parts:

A customer needs a temperature stabilized, 635nm source capable of delivering 10mW power with 1mm beam diameter.

Bar Code	Part Number	Description
37015	OZ-5000-635-10-1	Free space 635 nm, 10 mW laser module, 1 mm beam diameter

Frequently Asked Questions (FAQs)

Q: Can I use the laser ON/OFF control signal as a TTL input for modulation?

A: No, although the control signal is TTL compatible, it should only be used for turning the unit on or off through a digital interface or via a safety switch.

Q: Do the sources have a modulation function?

A: A standard OZ-5000 can be modulated at low frequencies by feeding the modulation signal to the power control input.

The power control signal varies the output power from 100% to 0% as the voltage changes from 0 volts to 5 volts. Most applications using modulation would require a modulation signal with a DC offset. The standard units use filters to minimize noise in the drive circuitry so as to give the cleanest possible optical signal. However, these filters also limit the bandwidth of the output. For applications that require a higher modulation capability, the bandwidth limitation can be reduced at the factory, to allow modulation of over 100 kHz except for 532 nm wavelengths. Special versions can be built using dedicated circuitry to allow up to 150MHz. Contact OZ Optics if modulation above a few kHz is required.

Q: Many laser diodes require less than 100 mA. Why does the OZ-5000 require >1 Amp?

A: Most of the current required by the OZ-5000 is used by the Peltier element that maintains the laser at a constant operating temperature. A constant temperature is required to ensure the best possible stability, both in terms of power stability and wavelength stability. Under certain conditions, the Peltier element may require a significant current. This is especially true when the laser is first turned on, and the Peltier driver circuitry is working hard to achieve the desired operating temperature. Once the desired temperature is reached, the operating current will generally drop significantly.

Q: Can OZ Optics manufacture sources using a customer supplied laser diode?

A: Yes. Please provide OZ Optics with detailed information.

Q: Does OZ Optics offer higher power sources than what is standard on the data sheet?

A: Yes. Please provide OZ Optics with the requested output power and beam diameter and we will work with you to find a solution.



* This module sold for OEM applications; purchaser is responsible for compliance with all safety regulations.